

Strategies For Reducing Procurement Costs

How to Reduce Costs Improving the Efficiency of Motor Components Procurement



***DFM and Motor Manufacturing
Solution for medium and small
size manufacturers***

Synopsis

Challenges

The presentation will focus on the difficulties during the early stage of motor developing

Solution

The proposed solution is to cope with the challenges in medium and small size manufacturers

DFM Activity

By considering factors influential to manufacturing, the DFM activity could help facilitating production feasibility and reducing manufacturing cost.

A person is rappelling down a dark, textured rock face. The person is wearing a harness and is positioned in the upper right quadrant of the image. The background is a clear, bright blue sky. The overall scene conveys a sense of challenge and adventure.

Challenges

Challenges in electrical motor OEMs during early developing stage
Background Description



Feasibility

- ⊗ · Slot Fill
- ⊗ · Wire Dia.
- ⊗ · Slot Open
- ⊗ · Rotor Segments Assembly Method
- ⊗ · Magnet Type And Grade
- ⊗ · Magnet Bonding Method

COST



NIDE
JUST FOR EASY

Concept and experience

Concept and experience in Design for Manufacturing (DFM)

DFM Concept Illustration

www.nidegroup.com

Traditional Method



DFM Method

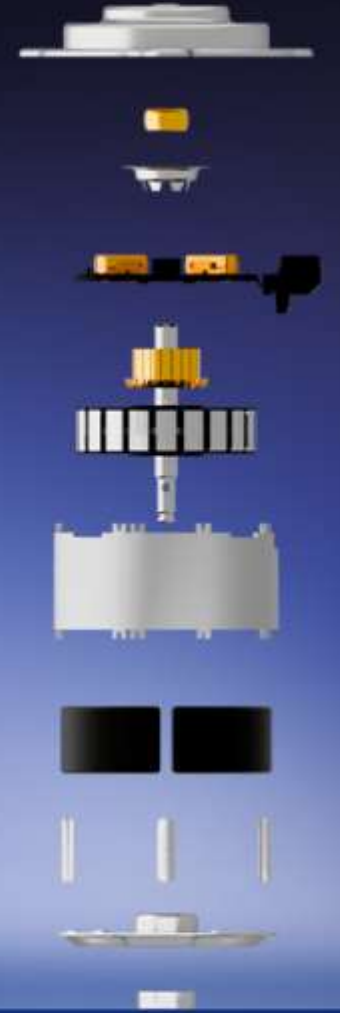
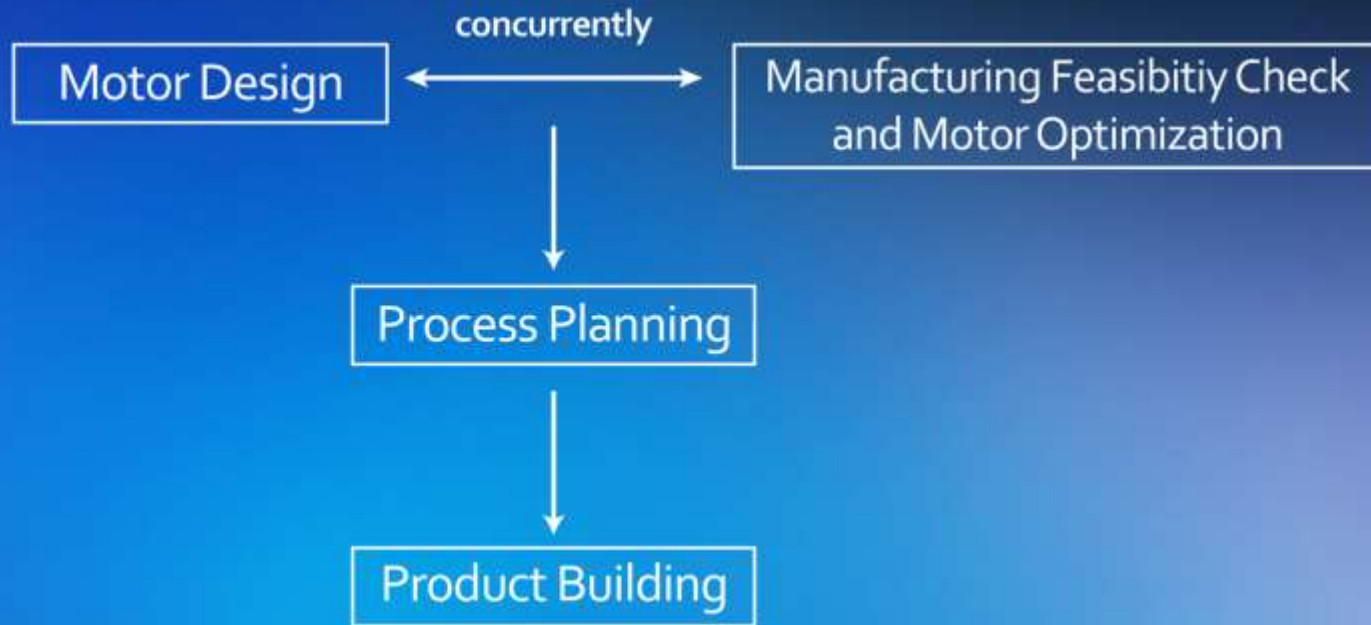

Comparison

	Traditional Method	DFM Method
Developing Cycle	long	short
Product Iteration	slow and difficult	quick and easy
Cost	difficult to control	easy to control

Solution

Nide's practice

Solution for motor development and Nide's practice;
Experience and Practice

Practice

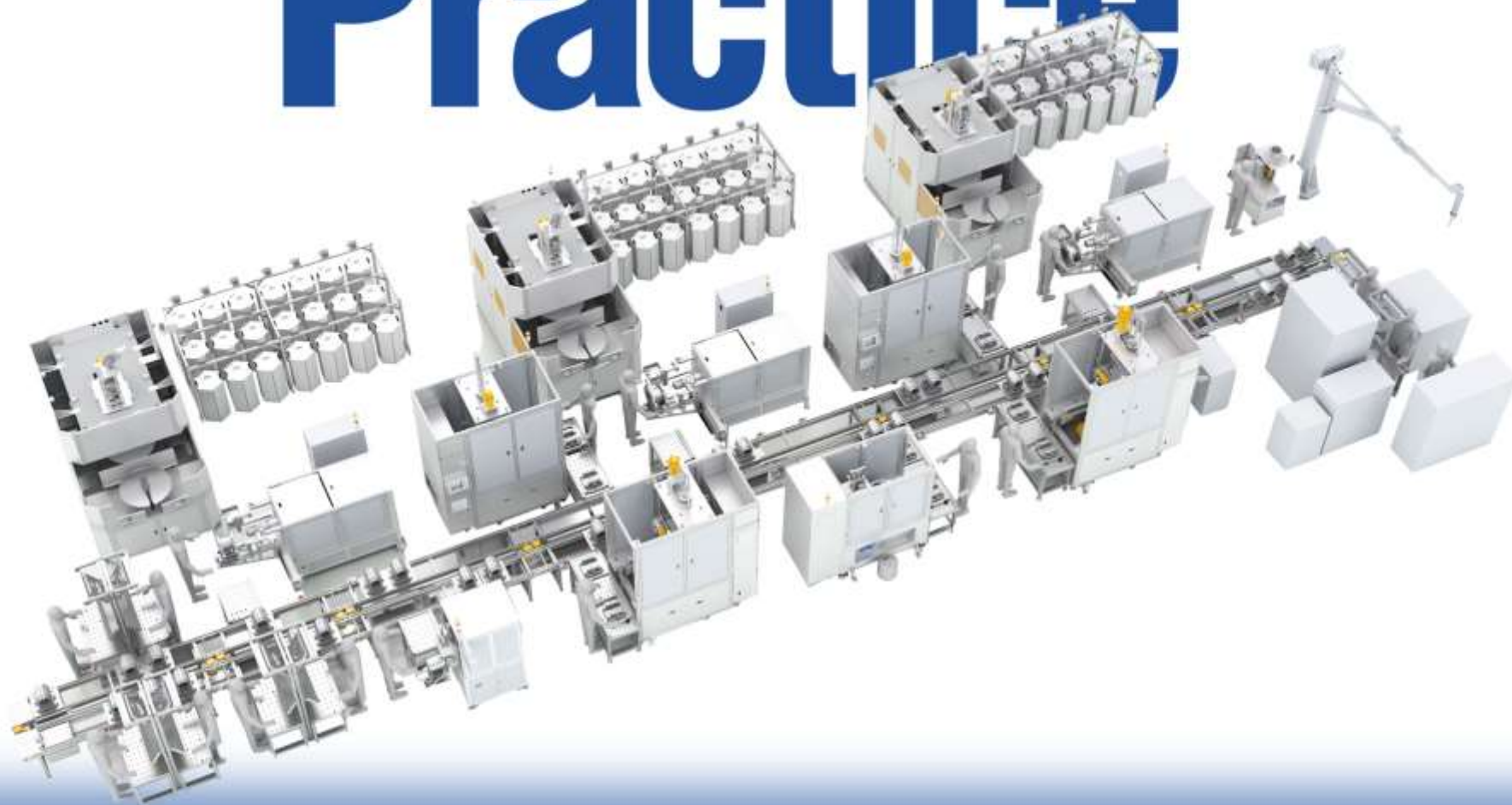

Project example

DFM Process

product	layers	bare wire diameter (mm)	insulated wire diameter (mm)	strands	turns	slot area (total)	slot area (active)	wire area (circle, only copper)	Fill Factor	Minimum Slot opening	fill factor	slot opening	others (diameter etc.)
1	1	0.71	/	22	3	150	60	26.13	43.6%	4.5mm	OK	4.5mm minimum	Too much wire with rather big diameter, easily causing overlap
2	1	1.35	/	1	20	150	60	28.63	47.7%	2.5mm	OK	OK	OK
3	1	1.65	/	1	13	150	60	27.80	46.3%	3.5mm	OK	OK	OK
4	1	1.9	/	1	10	150	60	28.35	47.3%	5mm 3.5mm	OK	OK	Wire Diameter too big to wind.

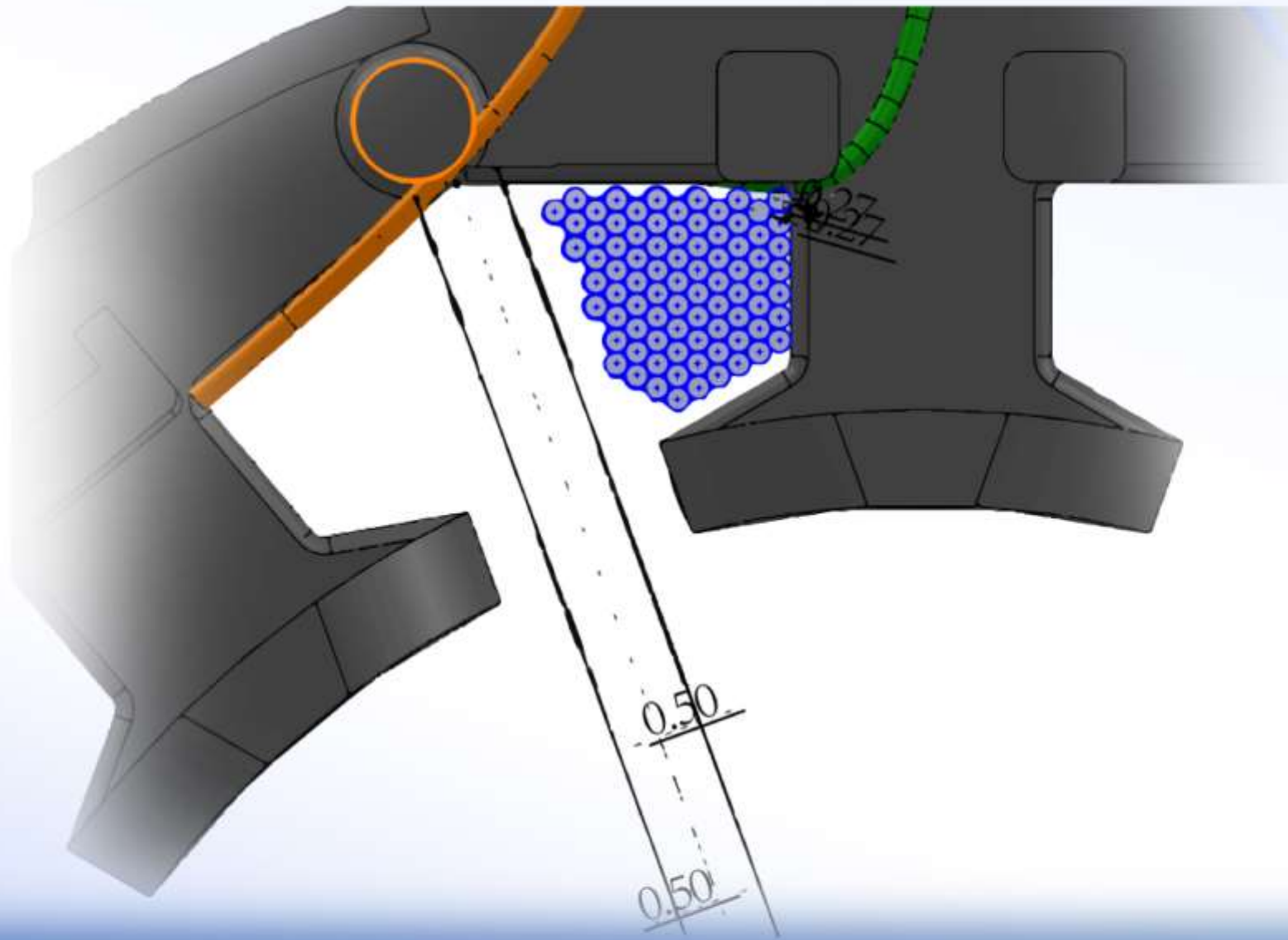

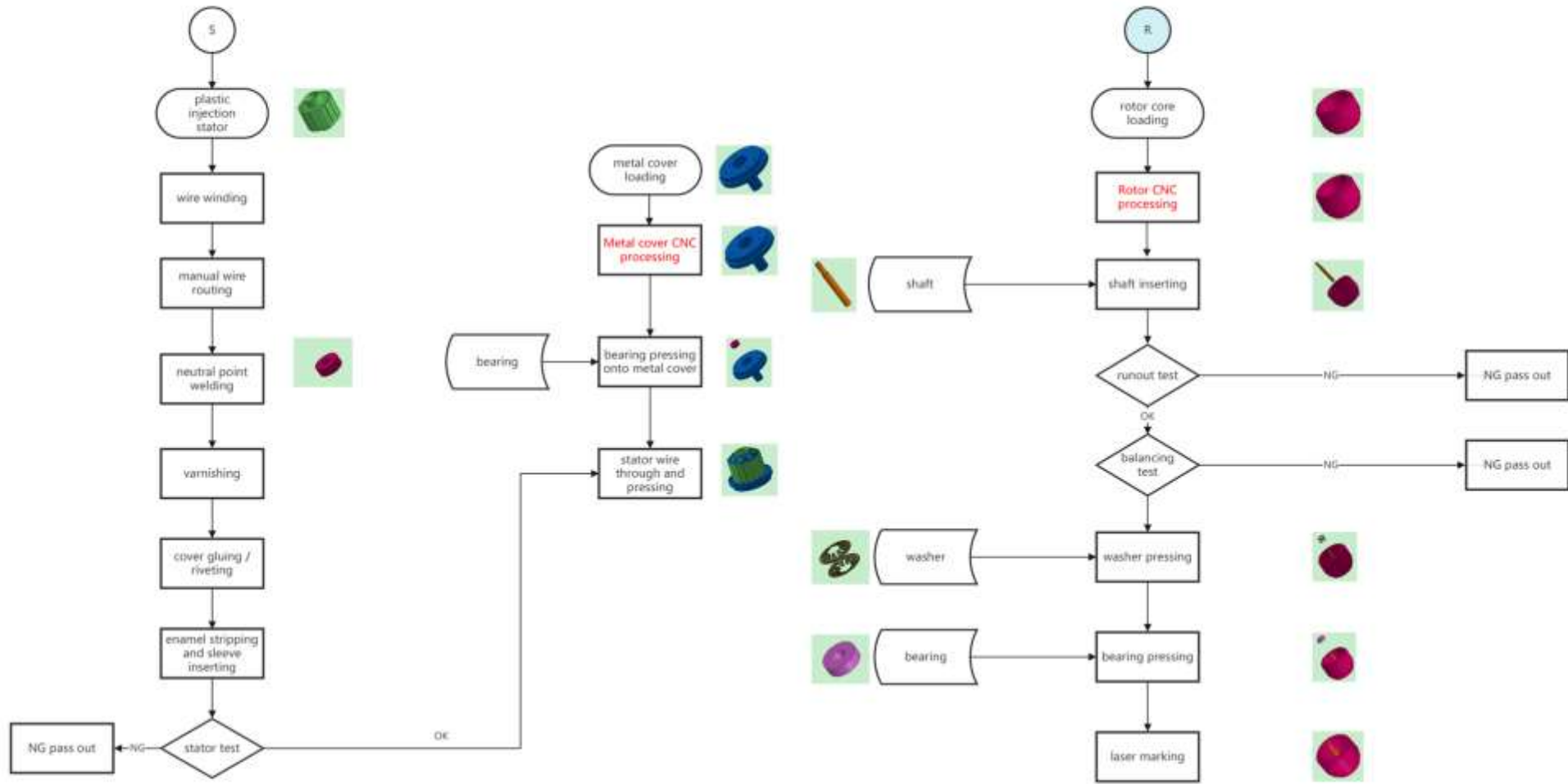

DFM Process

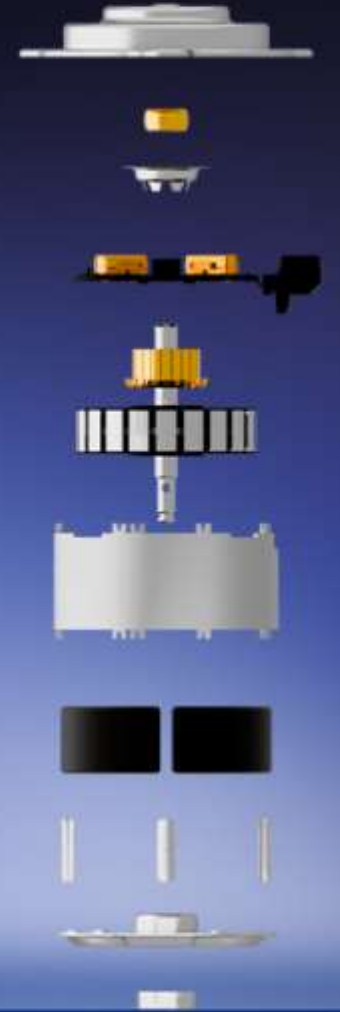
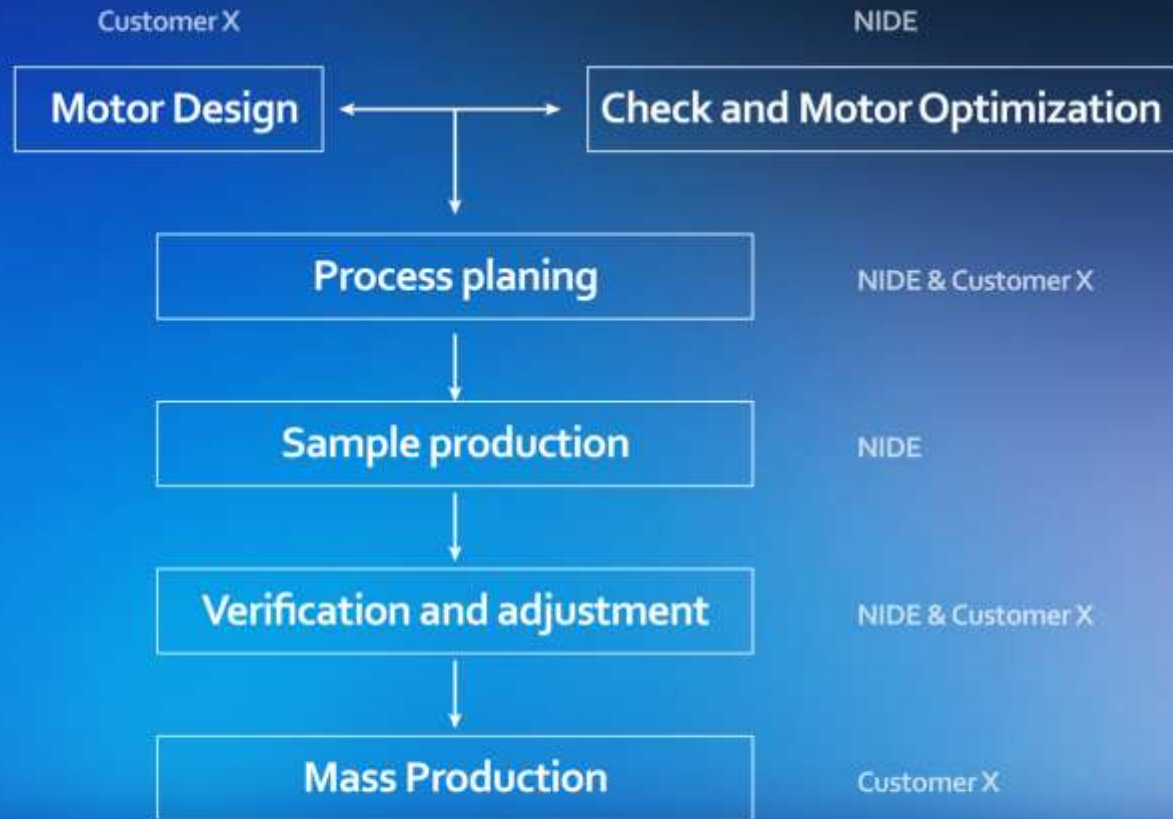

DFM Method

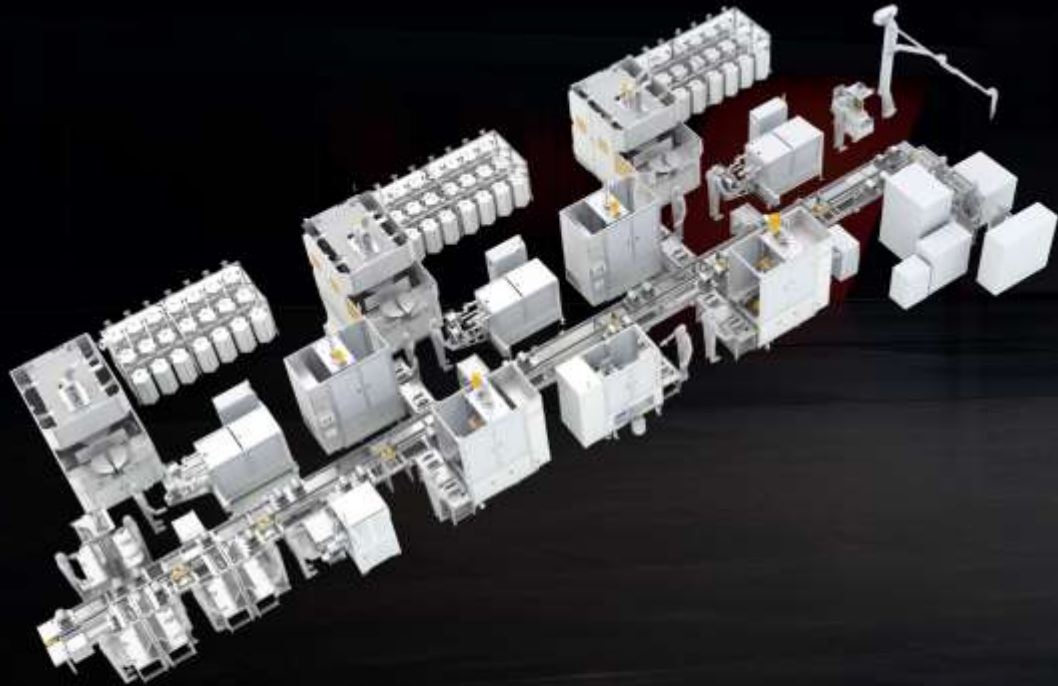

- Station by station customization
- Personalized configuration of the production line
- Virtual assembly, logistics simulation, digital planning
- Automation system interconnection with storage system

A silhouette of a person standing on the peak of a mountain, looking out over a vast, dark landscape. The word "Future" is written in large, white, sans-serif font across the center of the image, with the person's silhouette positioned in the middle of the letters 't' and 'u'.

Future

Outlook for future motor manufacturing

Outlook

Design in Future

DFL (Design for Life Cycle)

DFC (Design for Competitiveness)

DFM (Design for Manufacturing)

DFA (Design for Assembly)

DFI (Design for Inspection)

DFS (Design for Service)

DFR (Design for Recycling)

DFQ (Design for Quality)

DFMA = DFM + DFA

Life Cycle Engineering Design



Thank You!

张恒 Herbert Zhang, Vice Marketing Director
Ningbo Nide Mechanical Equipment Co.,Ltc
Mob/Whatsapp : 0086-15067409300

E-mail: marketing8@nide-group.com
Web: www.nidegroup.com



*Save up to **30%** Costs on
Motor Components Purchasing*

*Save up to **30%** Costs
on Motor Components Purchasing*

Guten Tag

NIDE
JUST FOR EASY

Eddy Kong

Greetings from Ningbo



the Largest Port on the Planet



  **CWIEME**
SHANGHAI

90 Miles

 **NIDE**

 **Ningbo Port** 

 5 Miles

NIDE
JUST FOR EASY

***Electric Motor
One-Stop Solution Provider***





*Un-Qualified
Products*



*Un-Reasonable
Extra Costs*



*Un-Bearable
Delay*



*What **pains** us **trains** us*



*COVID
Pandemic*



*Anti
Globalization*



*Regional
Conflicts*



*Nord Stream
Sabotage*



*Global
Inflation*

Struggles of Small & Medium-sized Enterprises



*Inefficient
Procurement*



*Middlemen
Increase Cost*



*Uncontrollable
Timeline*



*Unqualified
Products*



*Suppliers Lack
of Credit*



*Trade
Fraud*

Deficiencies in the Traditional Procurement Model

Find Suppliers



 **THE WORLD BANK**
IBRD • IDA
Data Source

Percentage of Top Ten Manufacturing Countries

Factory of the World



CWIEME
BERLIN

NIDE

MCP

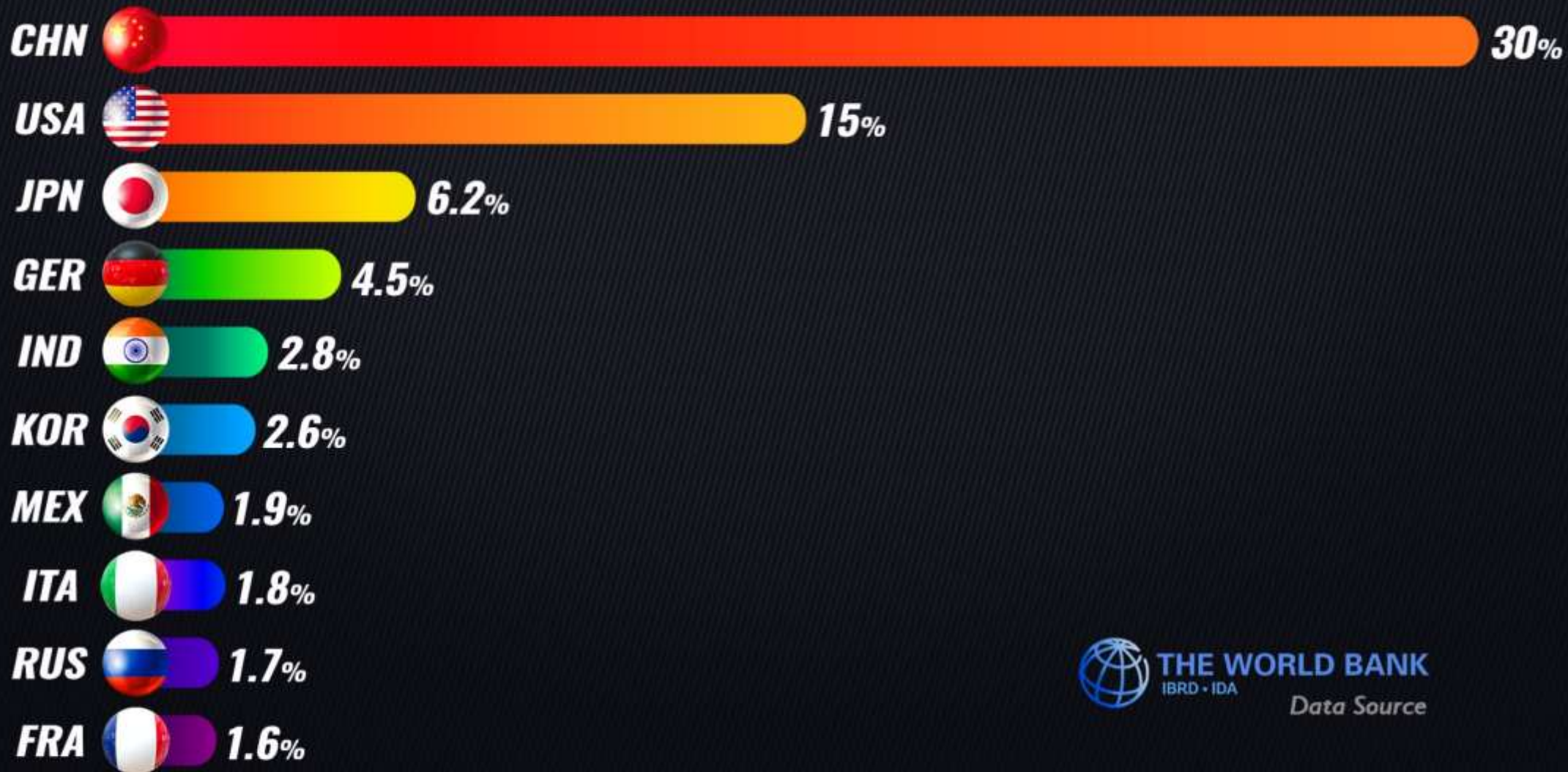

 **THE WORLD BANK**
IBRD • IDA
Data Source

Percentage of Top Ten Manufacturing Countries



3
Japan



4
Germany



5
India



6
Korea



7
Mexico



8
Italy



9
Russia



10
France



11
UK



12
Indonesia



13
Brazil



14
Ireland



15
Turkey



16
Canada



17
Spain

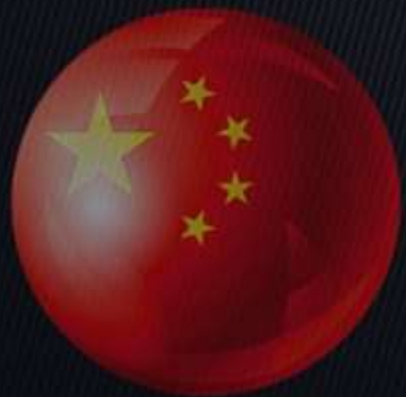

3
Japan



4
Germany



5
India



6
Korea



7
Mexico



8
Italy



9
Russia



10
France



11
UK



12
Indonesia



13
Brazil



14
Ireland



15
Turkey



16
Canada



17
Spain



4,975,614,346,583 🇨🇳 50X

101,216,657,151 🇻🇳 1X

US Dollar Millions

Made In China & Made In Vietnam





CWIEME
BERLIN



CWIEME
SHANGHAI

MagLev & CRH Train

 CRH 450KM/H



BEV Battery Electric Vehicle

 NIO NIO EP-9 2016 Model



Teleoperated Drone

DJI DJI Mavic 2020



Inefficiency

DHgate

Made-in-China

Alibaba

global sources

500,000,000+

Billions of Products Available Online in China

CWIEME
BERLIN

NIDE
JUST FOR EASY

MCP

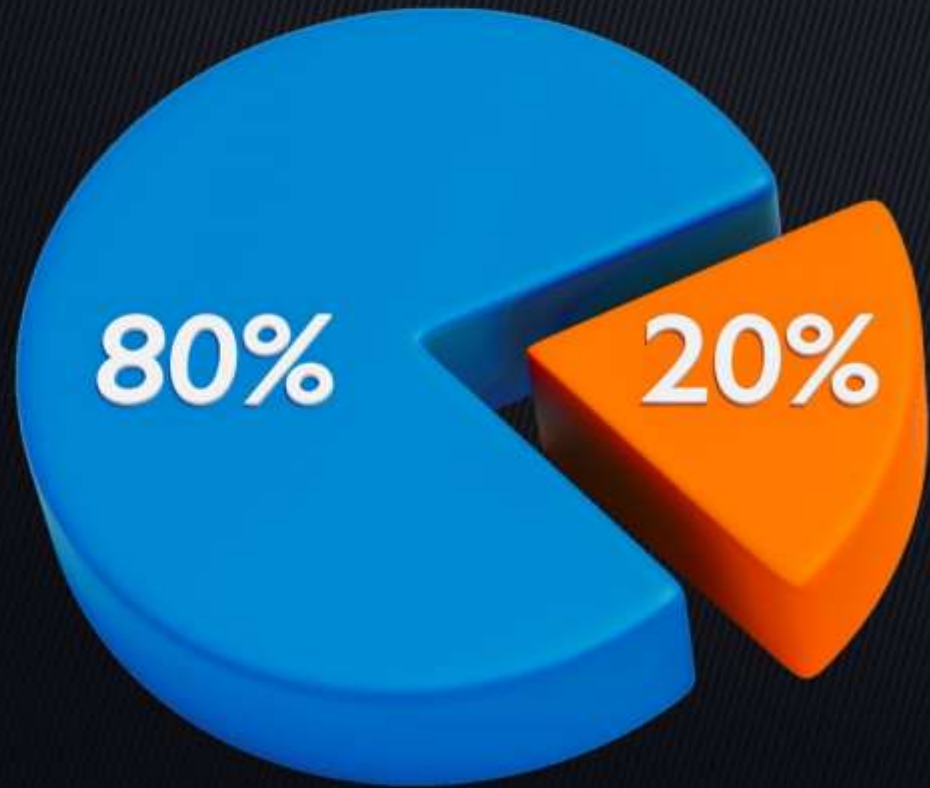

80/20
Principle
(Pareto Principle)



500,000,000+



Risks & Frauds



Lucas

Lucas Trade Limited

CEO

Lucas

CFO



Lucas

COO



Lucas

CMO



Lucas

the
Security



Lucas

the
Janitor



Lucas

Production
Manager



Lucas

the
Courier



6,877,000

Registered Chinese Foreign Trade Companies and Counting

Lucas

Decent & Solid Gentleman

Fine Young Fella



6,877,000

Registered Chinese Foreign Trade Companies and Counting

Freelancer

Part Time Trader

SOHO

Small Office Home Office

Broker

Personal Agent



 CWIEME
BERLIN

 NIDE
JUST FOR EASY

 MCP
MCP

A blue alien with large, expressive eyes and a wrinkled forehead is depicted in a professional office setting. The alien is wearing a dark suit, a light-colored shirt, and a headset with a microphone. It is seated at a desk, holding a thin cable in its hands. In front of the alien is a computer monitor and a keyboard. A desk lamp is positioned to the left, casting a warm glow on the scene. The background is dark and out of focus, suggesting an office environment.

You'll never know
who is on the other end
of the phone or the Internet cable.



or **what?**



*Inefficient
Procurement*



*Middlemen
Increase Cost*



*Uncontrollable
Timeline*



*Unqualified
Products*



*Suppliers Lack
of Credit*



*Trade
Fraud*

Deficiencies in the Traditional Procurement Model

MCPP

A NIDE BRAND

Motor Components Purchasing Platform

<http://www.MCPP.app>



NIDE
JUST FOR EASY

**Electric Motor
One-Stop Solution Provider**

CWIEME
BERLIN

NIDE
MOTOR

MCP

NIDE
JUST FOR EASY

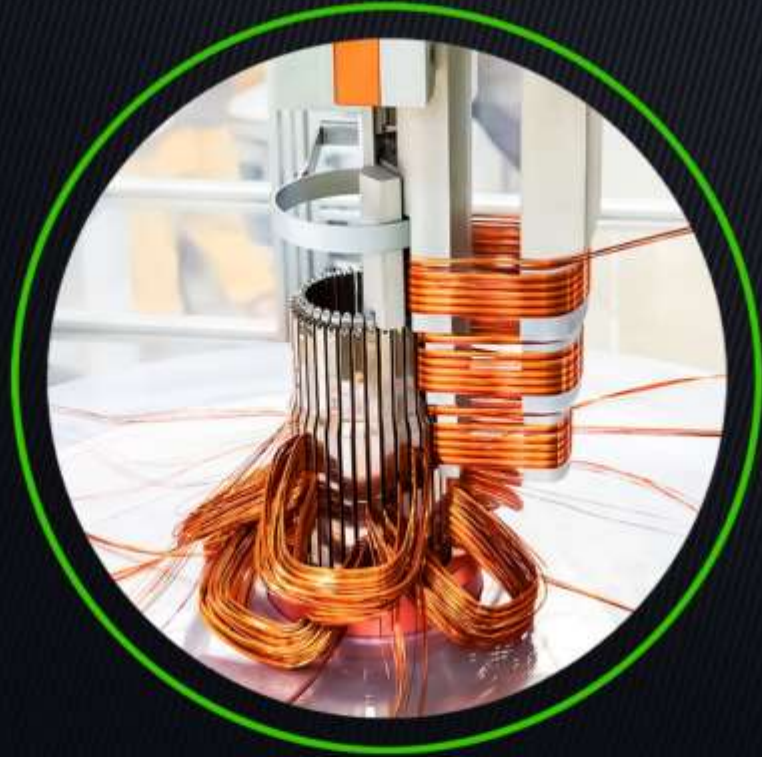

***Electric Motor
Manufacturing Equipments***

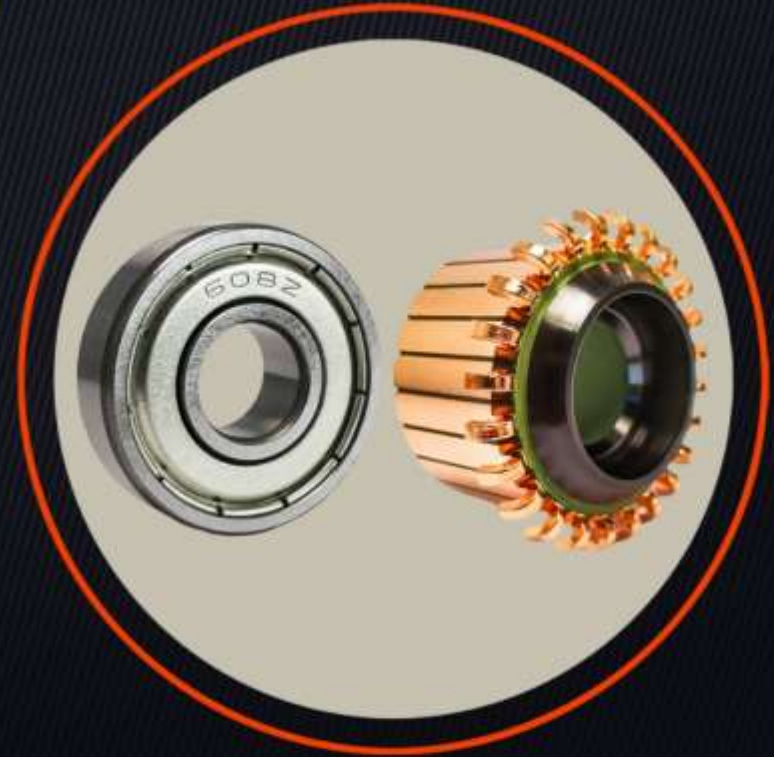

***Electric Motor
Components***



Empowers the Cyber World

CWIME WIDE MCPP



NIDE
inside





United States

Mexico

Brazil

Argentina

Italy

Swiss

Turkey

Russia

India

Thailand

Vietnam

Korea

NIDE



United States

Mexico

Brazil

Argentina

Italy

Swiss

Turkey

Russia

India

Thailand

Vietnam

NIDE

Korea

3955

Satisfied Partners & Counting

ABB

Nidec

Panasonic

PHILIPS

SIEMENS

TOSHIBA

SEW
EURODRIVE

Whirlpool

 **EMERSON**



Premium Quality

Cost Saving



Cut the Middle Men Out

 *Many a little
makes a much!*





Cut the *Middle Men* Out

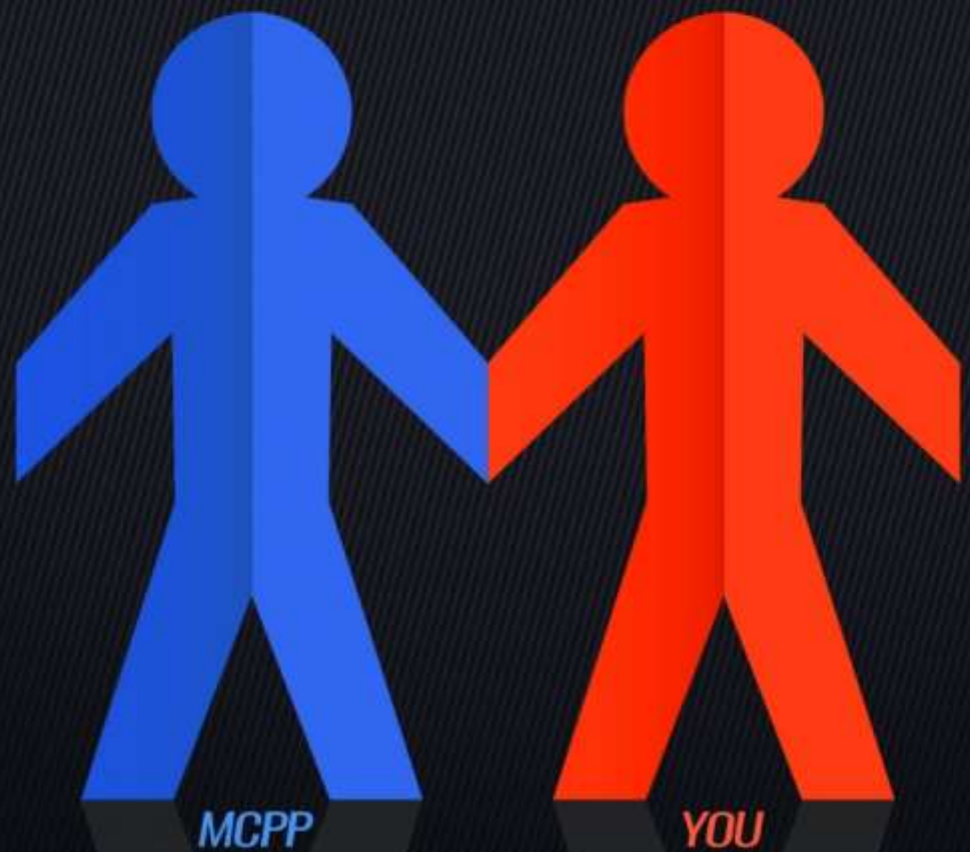

Find us, Find the Source

30%

Save up to 30%

W/EME NIDE MCPP
BERLIN



Your Cost, We Save.

Time Saving



Commutator

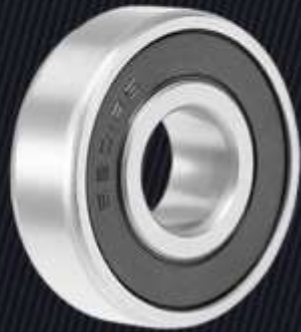

Bearing



Thermal Protector



Magnet

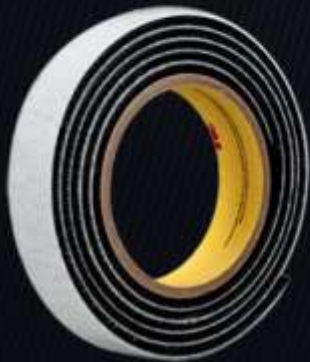

Insulation



Carbon Brush



Shaft



More Category

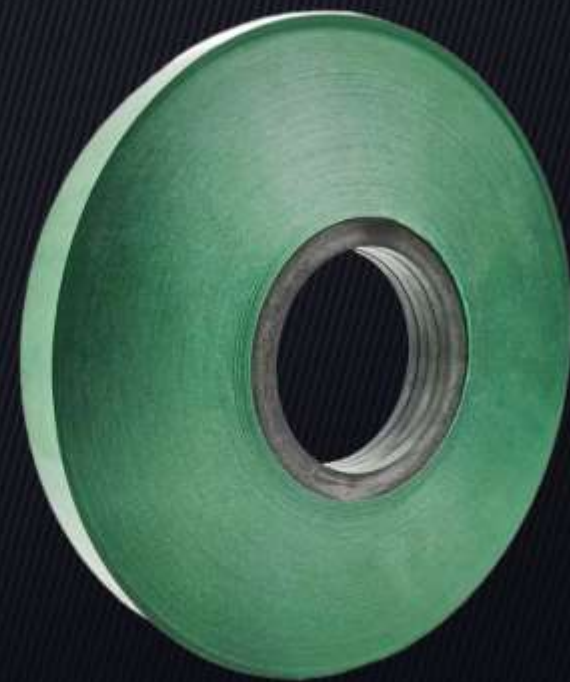

Featured Products



Deliver Your Order ASAP

24 x 365

Deliver Your Order ASAP

100%
Hassle-Free

How to use the **M CPP** service



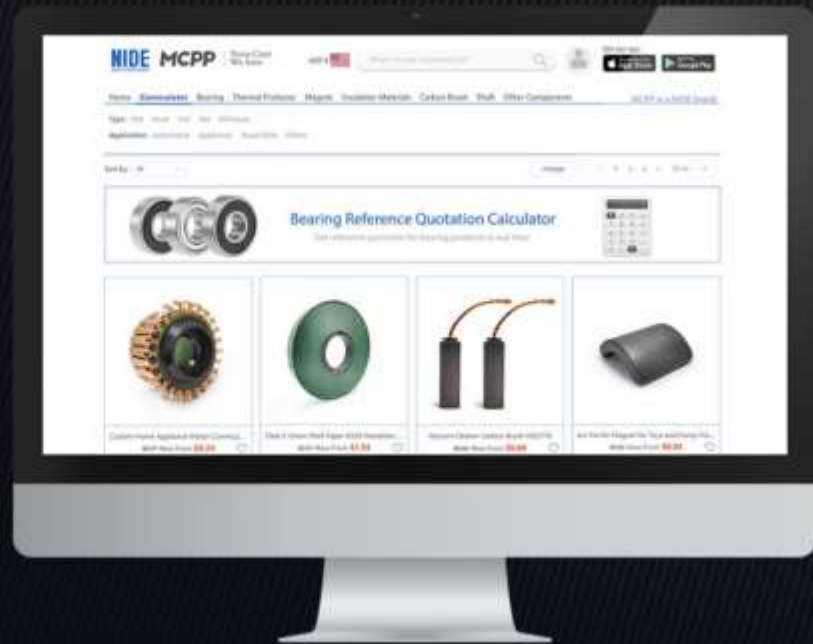

Desktop

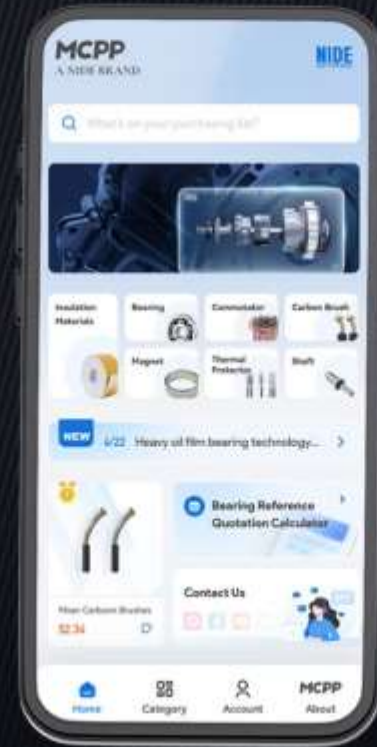

Mobile



<http://www.MCPP.app>



Desktop



Mobile



Android App



iOS App



12

Branch Offices

20

Years Experience

30

Save 30% Cost

50

Sales Networks

Summarize

3955

Partners



Sales@MCPP.app



+86 137 3886 9026



Jack Zeng

Happy Components Hunting



Less Fossil Fuel
♥ Make Our
Mother Earth
A Better Place 😊

NIDE
JUST FOR EASY

MCPPP



Visit Our Booths



Question & Answer